

DRAFT

INTERNATIONAL  
STANDARD

ISO/ASTM  
DIS  
51631

ISO/TC 85

Secretariat: **AFNOR**

Voting begins on:  
**2011- -**

Voting terminates on:  
**2011- -**

---

---

## Practice for use of calorimetric dosimetry systems for electron beam dose measurements and routine dosimetry system calibration

Pratique de l'utilisation des systèmes dosimétriques calorimétriques pour des mesures de dose délivrée par un faisceau d'électrons et pour l'étalonnage de dosimètres

RECIPIENTS OF THIS DOCUMENT ARE INVITED TO SUBMIT, WITH THEIR COMMENTS, NOTIFICATION OF ANY RELEVANT PATENT RIGHTS OF WHICH THEY ARE AWARE AND TO PROVIDE SUPPORTING DOCUMENTATION.

IN ADDITION TO THEIR EVALUATION AS BEING ACCEPTABLE FOR INDUSTRIAL, TECHNOLOGICAL, COMMERCIAL, AND USER PURPOSES, DRAFT INTERNATIONAL STANDARDS MAY ON OCCASION HAVE TO BE CONSIDERED IN THE LIGHT OF THEIR POTENTIAL TO BECOME STANDARDS TO WHICH REFERENCE MAY BE MADE IN NATIONAL REGULATIONS.



Reference number  
ISO/ASTM DIS 51631:2011(E)

© ISO/ASTM International 2011

**PDF disclaimer**

This PDF file may contain embedded typefaces. In accordance with Adobe's licensing policy, this file may be printed or viewed but shall not be edited unless the typefaces which are embedded are licensed to and installed on the computer performing the editing. In downloading this file, parties accept therein the responsibility of not infringing Adobe's licensing policy. Neither the ISO Central Secretariat nor ASTM International accepts any liability in this area.

Adobe is a trademark of Adobe Systems Incorporated.

Details of the software products used to create this PDF file can be found in the General Info relative to the file; the PDF-creation parameters were optimized for printing. Every care has been taken to ensure that the file is suitable for use by ISO member bodies and ASTM members. In the unlikely event that a problem relating to it is found, please inform the ISO Central Secretariat or ASTM International at the addresses given below.

**Copyright notice**

This ISO/ASTM document is a Draft International Standard and is copyright-protected by ISO and ASTM International. Except as permitted under the applicable laws of the user's country, neither this ISO/ASTM draft nor any extract from it may be reproduced, stored in a retrieval system or transmitted in any form or by any means, electronic, photocopying, recording or otherwise, without prior written permission being secured.

Requests for permission to reproduce should be addressed to either ISO at the address below or ISO's member body in the country of the requester. In the United States, such requests should be sent to ASTM International.

ISO copyright office  
Case postale 56 • CH-1211 Geneva 20  
Tel. +41 22 749 01 11  
Fax +41 22 749 09 47  
E-mail [copyright@iso.org](mailto:copyright@iso.org)  
Web [www.iso.org](http://www.iso.org)

ASTM International,  
100 Barr Harbor Drive, PO Box C700,  
West Conshohocken, PA 19428-2959,  
USA  
Tel. +610 832 9634  
Fax +610 832 9635  
E-mail [khooper@astm.org](mailto:khooper@astm.org)  
Web [www.astm.org](http://www.astm.org)

Reproduction may be subject to royalty payments or a licensing agreement.

Violators may be prosecuted.

## Explanatory Material

This international standard is part of the Pilot Project between ISO and ASTM International to develop and maintain a group of ISO/ASTM dosimetry standards for radiation processing. In accordance with ISO/TC 98 N 928, *Maintenance Procedures for ISO/ASTM Radiation Processing Dosimetry Standards*, a meeting of ASTM Subcommittee E10.01 Task Group H, which is responsible for this standard, was held in Tampa, Florida, in January 2008, to give the standard its Systematic Review. It was decided that this standard be revised to make it more informative, and to ensure that it is compatible with on-going developments of the top-tier standards. Users and manufacturers of other systems have therefore actively participated in the revision.

Editorial changes were made to the standard, and the standard was then submitted for Subcommittee ballot. This resulted in many valuable comments, and two negative votes.

Comments received through the Subcommittee ballot were considered and, where possible, accommodated at the meeting held in St. Louis, June 2010. The negative votes were first addressed, and then the text was modified in the light of the further comments as considered appropriate. The result was a version the subcommittee agreed should be submitted for ASTM Committee ballot and concurrent ISO DIS ballot.

A statement was added to the Scope to emphasize that this standard is one of a set of standards that provides recommendations for properly implementing dosimetry in radiation processing and is intended to be read in conjunction with the new ASTM Practice E 2628 "Practice for Dosimetry in Radiation Processing". A statement was added to the Scope to identify the new classification for this type of Dosimetry system. Definitions were updated to reflect current changes. Calorimeter was changed to calorimetric dosimeter system throughout the document. An annex was added to provide an example of a calibration verification of a calorimetric dosimetry system.

<b>Contents</b>	Page
<b>1</b> Scope .....	<b>1</b>
<b>2</b> Referenced documents .....	<b>1</b>
<b>3</b> Terminology .....	<b>2</b>
<b>4</b> Significance and use .....	<b>2</b>
<b>5</b> Interferences .....	<b>2</b>
<b>6</b> Apparatus .....	<b>3</b>
<b>7</b> Calibration Procedures .....	<b>4</b>
<b>8</b> Dose measurement procedures .....	<b>5</b>
<b>9</b> Calibration of other dosimeters .....	<b>7</b>
<b>10</b> Documentation .....	<b>7</b>
<b>11</b> Measurement uncertainty .....	<b>7</b>
<b>12</b> Keywords .....	<b>7</b>
<b>ANNEX</b> .....	<b>8</b>
<b>Bibliography</b> .....	<b>9</b>

## **Foreword**

ISO (the International Organization for Standardization) is a worldwide federation of national standards bodies (ISO member bodies). The work of preparing International Standards is normally carried out through ISO technical committees. Each member body interested in a subject for which a technical committee has been established has the right to be represented on that committee. International organizations, governmental and non-governmental, in liaison with ISO, also take part in the work. ISO collaborates closely with the International Electrotechnical Commission (IEC) on all matters of electrotechnical standardization.

Draft International Standards adopted by the technical committees are circulated to the member bodies for voting. Publication as an International Standard requires approval by at least 75% of the member bodies casting a vote.

ASTM International is one of the world's largest voluntary standards development organizations with global participation from affected stakeholders. ASTM technical committees follow rigorous due process balloting procedures.

A pilot project between ISO and ASTM International has been formed to develop and maintain a group of ISO/ASTM radiation processing dosimetry standards. Under this pilot project, ASTM Subcommittee E10.01, Dosimetry for Radiation Processing, is responsible for the development and maintenance of these dosimetry standards with unrestricted participation and input from appropriate ISO member bodies.

Attention is drawn to the possibility that some of the elements of this document may be the subject of patent rights. Neither ISO nor ASTM International shall be held responsible for identifying any or all such patent rights.

International Standard ISO/ASTM 51631 was developed by ASTM Committee E10, Nuclear Technology and Applications, through Subcommittee E10.01, and by Technical Committee ISO/TC 85, Nuclear energy.



# Standard Practice for Use of Calorimetric Dosimetry Systems for Electron Beam Dose Measurements and Routine Dosimetry System Calibration<sup>1</sup>

This standard is issued under the fixed designation ISO/ASTM 51631; the number immediately following the designation indicates the year of original adoption or, in the case of revision, the year of last revision.

## 1. Scope

1.1 This practice covers the preparation and use of semi-adiabatic calorimetric dosimetry systems for measurement of absorbed dose and for calibration of routine dosimetry systems when irradiated with electrons for radiation processing applications. The calorimeters are either transported by a conveyor past a scanned electron beam or are stationary in a broadened beam.

1.2 This document is one of a set of standards that provides recommendations for properly implementing dosimetry in radiation processing, and describes a means of achieving compliance with the requirements of ASTM Practice E2628 for a calorimetric dosimetry system. It is intended to be read in conjunction with ASTM Practice E2628.

1.3 The calorimeters described in this practice are classified as Type II dosimeters on the basis of the complex effect of influence quantities. See ASTM Practice E2628.

1.4 This practice applies to electron beams in the energy range from 1.5 to 12 MeV.

1.5 The absorbed dose range depends on the absorbing material and the irradiation and measurement conditions. Minimum dose is approximately 100 Gy and maximum dose is approximately 50 kGy.

1.6 The average absorbed-dose rate range shall generally be greater than 10 Gy·s<sup>-1</sup>.

1.7 The temperature range for use of these calorimetric dosimetry systems depends on the thermal resistance of the materials, on the calibrated range of the temperature sensor, and on the sensitivity of the measurement device.

1.8 *This standard does not purport to address all of the safety concerns, if any, associated with its use. It is the responsibility of the user of this standard to establish appropriate safety and health practices and determine the applicability of regulatory limitations prior to use.*

## 2. Referenced Documents

### 2.1 ASTM Standards:<sup>2</sup>

E170 Terminology Relating to Radiation Measurements and Dosimetry

E666 Practice for Calculating Absorbed Dose From Gamma or X Radiation

E668 Practice for Application of Thermoluminescence-Dosimetry (TLD) Systems for Determining Absorbed Dose in Radiation-Hardness Testing of Electronic Devices

E2628 Practice for Dosimetry in Radiation Processing

E2701 Guide for Performance Characterization of Dosimeters and Dosimetry Systems for Use in Radiation Processing

### 2.2 ISO/ASTM Standards:<sup>2</sup>

51261 Guide for Selection and Calibration of Dosimetry Systems for Radiation Processing

51431 Practice for Dosimetry in Electron and X-Ray (Bremsstrahlung) Irradiation Facilities for Food Processing

51649 Practice for Dosimetry in an Electron Beam Facility for Radiation Processing at Energies Between 300 keV and 25 MeV

51707 Guide for Estimating Uncertainties in Dosimetry for Radiation Processing

### 2.3 International Commission on Radiation Units and Measurements (ICRU) Reports:<sup>3</sup>

ICRU Report 34 The Dosimetry of Pulsed Radiation

ICRU Report 35 Radiation Dosimetry: Electron Beams with Energies Between 1 and 50 MeV

ICRU Report 37 Stopping Powers for Electrons and Positrons

ICRU Report 44 Tissue Substitutes in Radiation Dosimetry and Measurements

ICRU Report 60 Fundamental Quantities and Units for Ionizing Radiation

ICRU Report 80 Dosimetry Systems for use in Radiation Processing

<sup>1</sup> This practice is under the jurisdiction of ASTM Committee E10 on Nuclear Technology and Applications and is the direct responsibility of Subcommittee E10.01 on Radiation Processing: Dosimetry and Applications, and is also under the jurisdiction of ISO/TC 85/WG 3.

Current edition approved by ASTM Dec. 1, 2010. Published XX XX 2011. Originally published as E 1631 – 94. ASTM E 1631 – 96 <sup>e1</sup> was adopted by ISO in 1998 with the intermediate designation ISO 15568:1998(E). The present International Standard ISO/ASTM 51631:2011(E) replaces ISO 15568 and is a major revision of the last previous edition ISO/ASTM 51631–2003(E).

<sup>2</sup> For referenced ASTM and ISO/ASTM standards, visit the ASTM website, [www.astm.org](http://www.astm.org), or contact ASTM Customer Service at [service@astm.org](mailto:service@astm.org). For *Annual Book of ASTM Standards* volume information, refer to the standard's Document Summary page on the ASTM website.

<sup>3</sup> Available from the Commission on Radiation Units and Measurements, 7910 Woodmont Ave., Suite 800, Bethesda, MD 20814, U.S.A.



### 3. Terminology

#### 3.1 Definitions:

3.1.1 *primary-standard dosimetry system*—dosimetry system that is designated or widely acknowledged as having the highest metrological qualities and whose value is accepted without reference to other standards of the same quantity.

3.1.2 *reference standard dosimetry system*—dosimetry system, generally having the highest metrological quality available at a given location or in a given organization, from which measurements made there are derived.

3.1.3 *transfer standard dosimetry system*—dosimetry system used as an intermediary to calibrate other dosimetry systems.

3.1.4 *type II dosimeter*—dosimeter, the response of which is affected by influence quantities in a complex way that cannot practically be expressed in terms of independent correction factors.

#### 3.2 Definitions of Terms Specific to This Standard:

3.2.1 *adiabatic*—no heat exchange with the surroundings.

3.2.2 *calorimeter*—assembly consisting of calorimetric body (absorber), thermal insulation, and temperature sensor with wiring.

3.2.3 *calorimetric body*—mass of material absorbing radiation energy and whose temperature is measured.

3.2.4 *calorimetric dosimetry system*—dosimetry system consisting of calorimeter, measurement instruments and their associated reference standards, and procedures for the system's use.

3.2.5 *endothermic reaction*—chemical reaction that consumes energy.

3.2.6 *exothermic reaction*—chemical reaction that releases energy.

3.2.7 *heat defect (thermal defect)*—amount of energy released or consumed by chemical reactions caused by the absorption of radiation energy.

3.2.8 *specific heat capacity*—amount of energy required to raise 1 kg of material by the temperature of 1 K.

3.2.9 *thermistor*—electrical resistor with a well-defined relationship between resistance and temperature.

3.2.10 *thermocouple*—junction of two metals producing an electrical voltage with a well-defined relationship to junction temperature.

3.3 Definitions of other terms used in this standard that pertain to radiation measurement and dosimetry may be found in ASTM Terminology E170. Definitions in E170 are compatible with ICRU Report 60; that document, therefore, may be used as an alternative reference.

### 4. Significance and use

4.1 This practice is applicable to the use of calorimetric dosimetry systems for the measurement of absorbed dose in electron beams, the qualification of electron irradiation facilities, periodic checks of operating parameters of electron irradiation facilities, and calibration of other dosimetry systems in electron beams. Calorimetric dosimetry systems are most suitable for dose measurement at electron accelerators utilizing conveyor systems for transport of product during irradiation.

NOTE 1—For additional information on calorimetric dosimetry system operation and use, see ICRU Report 80. For additional information on the use of dosimetry in electron accelerator facilities, see ISO/ASTM Practices 51431 and 51649, and ICRU Reports 34 and 35, and Refs (1-3).<sup>4</sup>

4.2 The calorimetric dosimetry systems described in this practice are not primary standard dosimetry systems. The calorimeters are classified as Type II dosimeters (ASTM E2628). They may be used as internal standards at an electron beam irradiation facility, including being used as transfer standard dosimetry systems for calibration of other dosimetry systems, or they may be used as routine dosimeters. The calorimetric dosimetry systems are calibrated by comparison with transfer-standard dosimeters.

4.3 The dose measurement is based on the measurement of the temperature rise in an absorber (calorimetric body) irradiated by an electron beam. Different absorbing materials are used, but the response is usually defined in terms of dose to water.

NOTE 2—The calorimetric bodies of the calorimeters described in this practice are made from low atomic number materials. The electron fluences within these calorimetric bodies are almost independent of energy when irradiated with electron beams of 1.5 MeV or higher, and the mass collision stopping powers are approximately the same for these materials.

4.4 The absorbed dose in other materials irradiated under equivalent conditions may be calculated. Procedures for making such calculations are given in ASTM Practices E666 and E668, and Ref (1).

4.4.1 Calorimeters for use at industrial electron accelerators have been constructed using graphite, polystyrene or a Petri dish filled with water as the calorimetric body (4-10). The thickness of the calorimetric body shall be less than the range of the electrons.

4.4.2 Polymeric materials other than polystyrene may also be used for calorimetric measurements. Polystyrene is used because it is known to be resistant to radiation (11) and because almost no exo- or endothermic reactions take place (12).

### 5. Interferences

5.1 *Extrapolation*—The calorimetric dosimetry systems described in this practice are not adiabatic, because of the exchange of heat with the surroundings or within the calorimeter assembly. The maximum temperature reached by the calorimetric body is different from the temperature that would have been reached in the absence of that heat exchange. The temperature drifts before and after irradiation are extrapolated to the midpoint of the irradiation period in order to determine the true temperature increase due to the absorbed dose.

5.2 *Heat Defect*—Chemical reactions in irradiated material (resulting in what is called the heat defect or thermal defect) may be endo- or exothermic and may lead to measurable temperature changes (3).

5.3 *Specific Heat Capacity*—The specific heat capacity of some materials used as a calorimetric body may change with accumulated absorbed dose, thereby affecting the response of

<sup>4</sup> The boldface numbers in parentheses refer to the bibliography at the end of this practice.



the calorimeters. This is notably the case for polymers, such as polystyrene, and it will therefore be necessary to recalibrate calorimetric dosimetry systems at intervals that will depend on the total accumulated dose.

**5.4 Influence Quantities**—The response of the calorimetric dosimetry systems to absorbed dose does not depend on environmental relative humidity and temperature.

**5.5 Temperature Effects from Accelerator Structure**—The calorimeters are often irradiated on a conveyor used for passing products and samples through the irradiation zone. Radiated heat from the mechanical structures of the irradiation facility and from the conveyor may contribute to the measured temperature increase in the calorimeters.

**5.6 Thermal Equilibrium**—The most reproducible results are obtained when the calorimeters are in thermal equilibrium with their surroundings before irradiation.

**5.7 Other Materials**—The temperature sensors, wires, etc. of the calorimeter represent foreign materials, which may influence the temperature rise of the calorimetric body. These components should be as small as possible.

**5.8 Dose Gradients**—Dose gradients will exist within the calorimetric body when it is irradiated with electrons. These gradients must be taken into account, for example, when other dosimeters are calibrated by comparison with calorimetric dosimetry systems.

## 6. Apparatus

**6.1 A Typical Graphite Calorimeter** is a disc of graphite placed in a thermally-insulating material such as foamed plastic (4-6). A calibrated thermistor or thermocouple is embedded inside the disc. Some typical examples of graphite disc thicknesses and masses are listed in Table 1 (2).

**6.2 A Typical Water Calorimeter** is a sealed polystyrene Petri dish filled with water and placed in thermally-insulating foamed plastic (4). A calibrated temperature sensor (thermistor) is placed through the side of the dish into the water. The shape and size of the water calorimeter can be similar to the shape and size of the polystyrene calorimeter (see 6.3).

**6.3 A Typical Polystyrene Calorimeter** is a polystyrene disc placed in thermally-insulating foamed plastic. A calibrated

thermistor or thermocouple is imbedded inside the disc. The dimension of the polystyrene disc may be similar to that of the graphite and water calorimeters (9). See Fig. 1 as an example of a 10 MeV-calorimeter. Fig. 2 shows an example of a polystyrene calorimeter designed for use at 1.5 to 4 MeV electron accelerators.

**6.4** The thickness of the calorimetric body should be less than the range of the irradiating electrons, typically not exceeding  $\frac{1}{3}$  of the range of the electrons. That will limit the variation of the dose gradients within the calorimetric body.

**6.5** Radiation-resistant components should be used for the parts of the calorimeter that are exposed to the electron beam. This also applies to insulation of electrical wires.

**6.6** Good thermal contact must exist between the temperature sensor and the calorimetric body. For graphite and polystyrene calorimeters, this can be assured by adding a small amount of heat-conducting compound when mounting the temperature sensor.

**6.7 Measurement**—The response of the calorimeters is the temperature rise of the calorimetric body. This temperature rise is usually registered by thermistors or thermocouples.

**6.7.1 Thermistor**—A high-precision ohm-meter can be used for measurement of thermistor resistance. The meter should have a reproducibility of better than  $\pm 0.1\%$  and an accuracy of better than  $\pm 0.2\%$ . It should preferably be equipped for four-wire type resistance measurements, especially if the thermistor resistance is less than 10 k $\Omega$ . With the four-wire measurement technique, the effects of resistance in the measurement wires and electrical contacts are minimized.

**6.7.2** Other appropriate instrumentation may be used for the thermistor resistance measurement, for example, a resistance bridge or commercially calibrated thermistor readers (5). It is important for both ohm-meters and resistance bridge measurements to minimize the dissipated power in the thermistor, preferably below 0.1 mW.

**6.7.3 Thermocouple**—A high-precision digital voltmeter, or commercial reader (2), can be used for the measurement. The reproducibility of the voltmeter should be better than 0.1  $\mu$ V, and an accuracy of better than  $\pm 0.2\%$ .

**TABLE 1 Thickness and size of several graphite calorimetric bodies designed at NIST for use at specific electron energies**

Electron Energy MeV	Electron Range in Graphite <sup>A</sup> density: 1.7 g cm <sup>-3</sup>		Calorimeter Disc (30 mm diameter)		
	g cm <sup>-2</sup>	cm	Thickness <sup>B</sup>		Mass, g
			g cm <sup>-2</sup>	cm	
4	2.32	1.36	0.84	0.49	5.9
5	2.91	1.71	1.05	0.62	7.5
6	3.48	2.05	1.25	0.74	8.9
8	4.59	2.70	1.65	0.97	11.7
10	5.66	3.33	2.04	1.20	14.4
11	6.17	3.63	2.22	1.31	15.7
12	6.68	3.93	2.40	1.41	16.9

<sup>A</sup> This is the continuous-slowing-down approximation (CSDA) range  $r_o$  of electrons for a broad beam incident on a semi-infinite absorber. It is calculated from:

$$r_o = \int_0^{E_0} (1 / (S(\rho)_{tot})) dE$$

where:

$E_0$  = the primary electron energy, and  
 $(S(\rho)_{tot})$  = the total mass stopping power at a given electron energy (1).

<sup>B</sup> The thicknesses specified are equal to 0.36  $r_o$ .



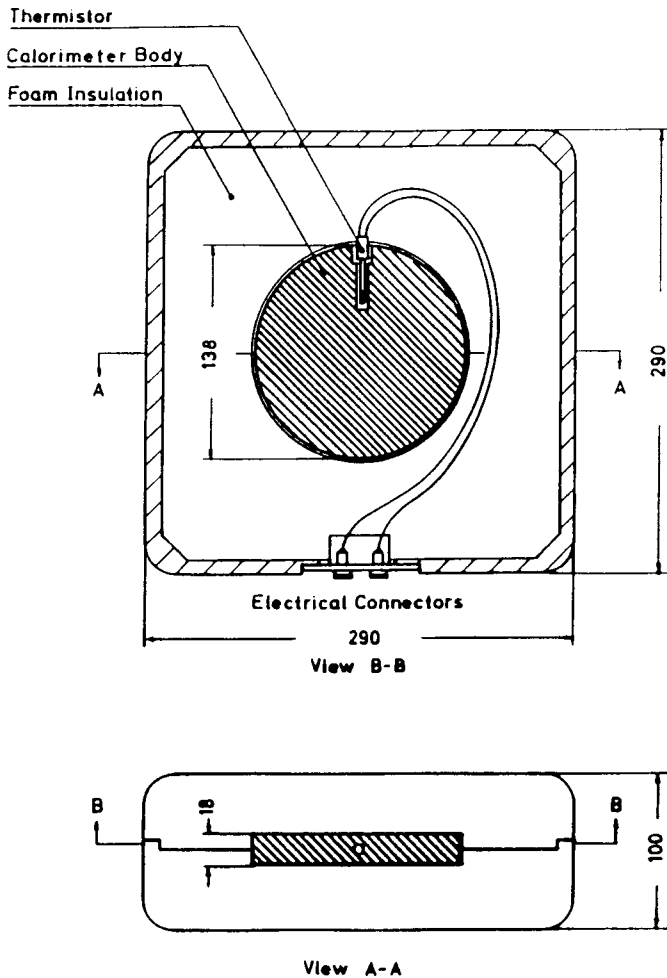

NOTE—All dimensions are in mm.

FIG. 1 Example of a polystyrene calorimeter used for routine measurements at a 10-MeV industrial electron accelerator

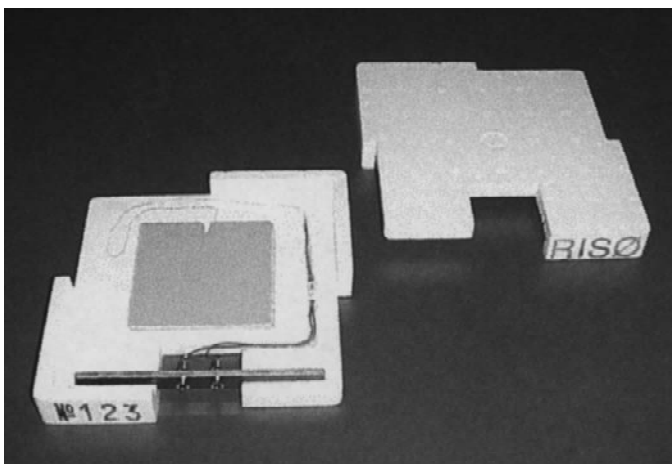

FIG. 2 Example of a polystyrene calorimeter for use at 1.5 to 4 MeV industrial electron accelerators (13)

6.7.4 *Suppliers*—Some commercial suppliers of calorimetric dosimetry systems are listed in Annex A2.

## 7. Calibration procedures

7.1 Prior to use, the calorimetric dosimetry system (consisting of calorimeter and measurement instruments) shall be calibrated in accordance with the user's documented procedure that specifies details of the calibration process and quality assurance requirements. This calibration process shall be repeated at regular intervals to ensure that the accuracy of the absorbed dose measurement is maintained within required limits. Calibration methods are described in ISO/ASTM Guide 51261.

7.2 Graphite, water or polystyrene calorimetric dosimetry systems may be calibrated by comparison with transfer standard dosimetry systems from an accredited calibration laboratory by irradiating the calorimeter(s) and transfer-standard dosimeters sequentially (or simultaneously) at an electron accelerator. The radiation field over the cross-sectional area of the calorimetric body shall be uniform over the time required to irradiate the calorimeters and the transfer-standard dosimeters. Any non-uniformity should be taken into account.

7.3 It must be assured that the transfer-standard dosimeters and the calorimeters are irradiated to the same dose. Specially designed absorbers are needed for irradiation of the transfer-standard dosimeters, see for example Fig. 3.

7.4 The specific heat capacities of polystyrene and of graphite are functions of temperature, while the specific heat capacity of water is almost constant within the temperature range normally employed in electron beam calorimetry. The calibration curves of the calorimetric dosimetry systems are therefore expected to be functions of the average temperature of the calorimetric body (see Note 3).

7.4.1 For graphite calorimetric dosimetry systems, the calibration curve may take the following form:

$$\text{Dose} = (T_2 - T_1 - T_a) \cdot c_G \cdot (S_{el/\rho})_W / (S_{el/\rho})_G \cdot k$$

where:

$T_1$	= temperature before irradiation,
$T_2$	= temperature after irradiation,
$T_a$	= temperature rise from irradiation facility components,
$c_G$	= specific heat capacity of graphite,
$S_{el/\rho}_W$ and $(S_{el/\rho})_G$	= are the electronic mass stopping powers of water and graphite, respectively, and
$k$	= calibration constant to be determined during calibration verification.

NOTE 3—Repeated measurements of specific heat of various types of graphite have been carried out over the range of 0 to 50°C, indicating a value for the specific heat capacity of graphite  $c_G$  ( $J \cdot kg^{-1} \cdot ^\circ C^{-1}$ ) =  $644.2 + 2.86 T$ , where  $T$  is the mean temperature ( $^\circ C$ ) of the graphite. This value must, however, not be considered a universal value (6).

7.4.2 For polystyrene calorimetric dosimetry systems, the calibration curve may take the following form:

$$\text{Dose} = (T_2 - T_1 - T_a) \cdot F(T) \cdot k$$

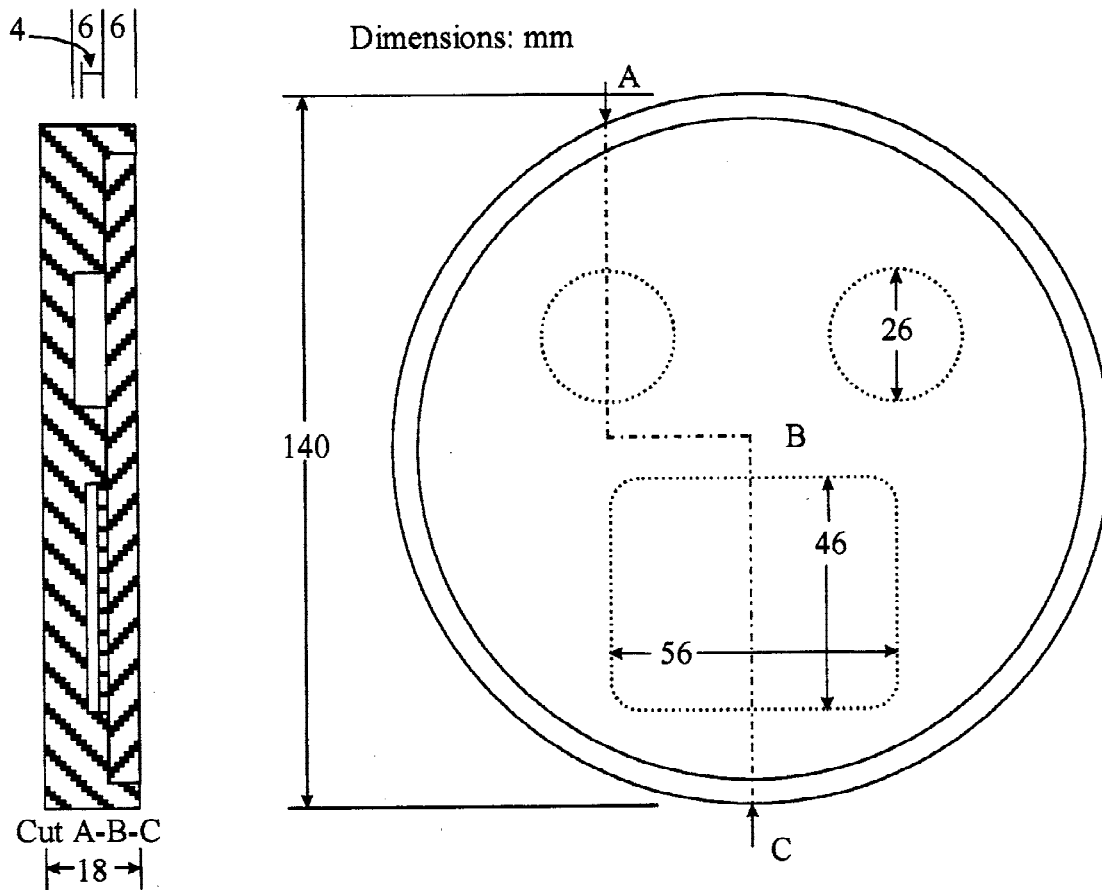

NOTE—All dimensions are in mm.

FIG. 3 Absorber for irradiation at 10 MeV electron accelerator of routine and transfer-standard dosimeters (10). Material: Polystyrene

where:

- $T_1$  = temperature before irradiation,  
 $T_2$  = temperature after irradiation,  
 $T_a$  = temperature rise from irradiation facility components,  
 $F(T)$  = function representing specific heat capacity of polystyrene, and  
 $k$  = calibration constant to be determined during calibration verification.

NOTE 4—The function  $F(T)$  takes the form  $F(T) = C1 + C2 \cdot T$ , where  $C1$  and  $C2$  are constants and  $T$  is the mean temperature ( $^{\circ}\text{C}$ ) of the calorimetric body. The values of  $C1$  and  $C2$  depend on the type of polystyrene used for making the calorimetric absorber.

NOTE 5— $T_a$  can be determined by passing a calorimeter through the irradiation zone shortly after the electron beam has been switched off, and measuring the temperature increase of the calorimetric absorber.

NOTE 6—The sensitivity of water calorimetric dosimetry systems is approximately  $3.4 \text{ kGy} \cdot ^{\circ}\text{C}^{-1}$  and for polystyrene calorimetric dosimetry systems it is approximately  $1.4 \text{ kGy} \cdot ^{\circ}\text{C}^{-1}$ . For graphite calorimetric dosimetry systems, the sensitivity is approximately  $0.75 \text{ kGy} \cdot ^{\circ}\text{C}^{-1}$ .

7.5 Calibration of all types of calorimetric dosimetry systems used as routine dosimetry systems should be checked by

comparison with reference standard or transfer standard dosimetry systems at a frequency determined by the user.

7.6 It is recommended that calibration of the calorimetric dosimetry system be carried out by irradiation at the user's facility in order for the effect of influence quantities to be minimized.

7.7 Calorimetric dosimetry systems may be calibrated by irradiation at a calibration laboratory. The calibration obtained in this way must be verified by simultaneous irradiation of the calorimeters and transfer-standard dosimeters at the user's facility.

7.8 An example of a calibration verification of a calorimetric dosimetry system is given in Annex A1.

7.9 *Measurement Instrument Calibration and Performance Verification*—For the calibration of the measuring instruments, and for the verification of instrument performance between calibrations, see ISO/ASTM Guide 51261 and/or instrument-specific operating manuals.

## 8. Dose measurement procedures

8.1 *Conveyor Irradiation Off-Line Measurements*—For calorimeters carried on conveyors through scanned electron

beams, the calorimeter is usually disconnected from the temperature measurement system just prior to irradiation and reconnected for measurement just after irradiation (7).

8.1.1 Before irradiation, measure the temperature of the calorimetric body and check that the temperature remains stable for a period of at least 10 min (typically less than 0.1°C change).

8.1.2 Disconnect the measurement wires and place the calorimeter on the conveyor for transport through the irradiation zone.

8.1.3 Transport the calorimeter through the irradiation zone on the conveyor system.

8.1.4 Record the time of irradiation, and the irradiation parameters (for example, electron energy, electron current, scanned beam width, and conveyor speed).

8.1.5 After passage of the calorimeter through the irradiation zone, reconnect the wires for measurement of temperature, record the temperature, and record the time from the end of irradiation to the first temperature measurement.

8.1.6 Record the temperature as a function of time for a period long enough to establish the thermal decay characteristics of the calorimeter. Typically 10-20 min are required.

8.1.7 Plot the temperature values as a function of time before and after irradiation.

8.1.8 Extrapolate the curves before and after irradiation to the midpoint of the irradiation time. The two values of temperature obtained from the extrapolations are used as the temperature before irradiation ( $T_1$ ) and after irradiation ( $T_2$ ) that would reflect the temperature rise solely due to absorbed dose. An example of data obtained by this measurement technique is shown in Fig. 4.

8.1.9 Based on the temperature difference,  $T_2 - T_1$ , determine the average absorbed dose in the calorimetric body from the calibration curve established in Section 7.

8.1.10 For well-established, reproducible irradiation conditions the extrapolation procedure of 8.1.6-8.1.8 may not be needed. One measurement of temperature before and one after irradiation may suffice, and the temperature difference at the time of irradiation is found by use of a correction factor derived during the establishment of the irradiation procedures (4,5,7,8). The times of the measurements should be specified.

8.1.11 Software can be developed by the user for the calculation of dose as measured with the calorimetric dosimetry systems. Suppliers of calorimetric dosimetry systems usually supply such software. An example is CALDOSE from Risø High Dose Reference Laboratory (Denmark).

8.2 *On-line Measurements*—It is possible to measure the temperature of the calorimetric body during irradiation as the calorimeter is transported through the irradiation zone on the conveyor with measurement wires attached. Four-wire measurement (see 6.7.1) may be preferred in order to reduce measurement uncertainty.

8.3 *Stationary Irradiation*—The calorimeters described in this practice may also be used in a stationary configuration instead of being transported on a conveyor system through the electron beam. In this arrangement the beam can be made uniform (see 8.3.2) over the area of the calorimetric body either

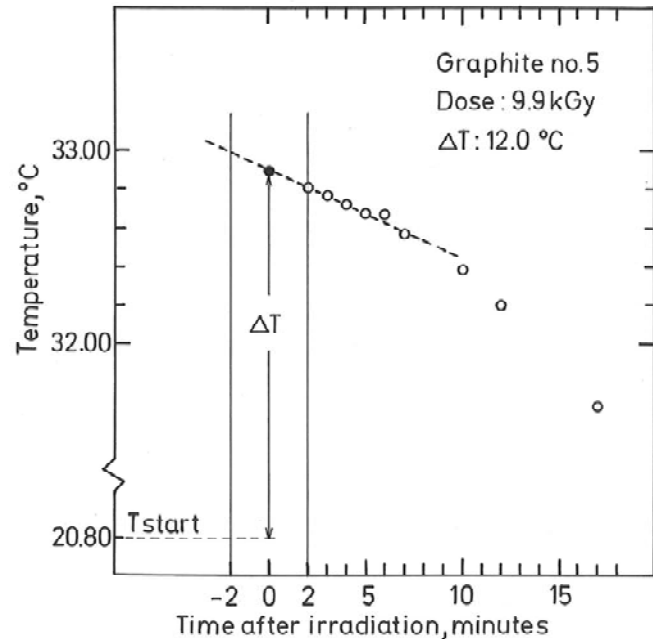

NOTE— $\Delta T$  is the temperature rise found by extrapolation and used for dose calculation (see 8.1.9). Wires were disconnected during irradiation.

FIG. 4 Example of measurements of temperature of a graphite calorimeter before and after irradiation only (7)

by the use of metallic scattering foils or by raster scanning. The irradiation period is controlled by turning the electron beam on and off.

8.3.1 The measurement of the temperature of the calorimeters in a stationary configuration may be done continuously before, during, and after irradiation rather than measuring only before and after irradiation as described in 8.1.

8.3.2 With the electron beam turned off, locate the calorimeter on the beam axis at an appropriate distance from the accelerator beam exit window such that the beam profile is uniform to within  $\pm 2\%$  across the diameter of the calorimeter body. The beam profile should be measured and if it varies more than  $\pm 2\%$  across the calorimeters, corrections for the non-uniformity may have to be carried out. If the temperature measurement system is located outside of the irradiation area for on-line measurement, and long connecting wires are used, then the use of four-wire measurement technique is essential.

8.3.3 Measure the temperature of the calorimetric body as a function of time to ensure that the initial drift rate is less than the desired limits (see 8.1.1).

8.3.4 With the calorimetric body temperature being recorded continuously, turn on the electron beam for the desired irradiation time. After the beam is turned off, continue recording the temperature for enough time to establish the thermal decay characteristics of the particular calorimeter being used. If continuous recording of data is not carried out, but data are instead recorded by intermittent electronic recordings, then account has to be taken of possible loss of data caused by excessive time interval between recordings.



8.3.5 Extrapolate the time versus temperature curves before and after irradiation to the midpoint of the irradiation time in the same manner as in 8.1.7. The average absorbed dose in the calorimetric body is calculated in the same manner as in 8.1.8 or 8.1.9. An example of data obtained by this measurement technique is shown in Fig. 5 (2,5).

## 9. Calibration of other dosimetry systems

9.1 The absorbed dose measured by the calorimetric dosimetry system is the average dose in the calorimetric body.

9.2 The calibrated calorimetric dosimetry systems may be used for calibration of other dosimetry systems at the same irradiation facility. They must be irradiated so as to receive the same average absorbed dose as the calorimeter when placed at specific depths in absorbers which simulate the calorimetric body (see Fig. 3). The dosimeters for calibration shall be small enough to fit inside the thickness of the absorber (1,5).

9.3 By successive (or simultaneous) irradiation of the absorber and the calorimeter under identical conditions, the dosimeters being calibrated are irradiated to the doses measured by the calorimeters.

9.4 A relation between the average dose in the calorimetric body and the dose delivered to the dosimeter being calibrated may be established, if the dose distribution throughout the calorimetric body is known and the dosimeter being calibrated is small. This dose distribution can be measured by irradiating a dummy calorimetric absorber containing a calibrated film dosimeter placed at an angle to the beam direction, and analyzing the film by scanning densitometry (7,14). If the dosimeter being calibrated is not small compared with the calorimeter absorber volume, then the average dose delivered

to the dosimeter must be related to the average dose delivered to the absorber by measurement of the dose distribution in both.

9.5 The mean temperature of the dosimeters during irradiation for calibration shall be determined (5). This is necessary if temperature corrections are to be applied.

## 10. Documentation

10.1 For the calibration and application of the calorimetric dosimetry systems, record or reference the temperature sensor calibration data and the calibration data for the calorimetric dosimetry systems. Record the total accumulated dose of the calorimeter. See 5.3.

10.2 Record or reference the irradiation date, temperature and time data, analysis instrumentation, dose interpretation of calorimetry data, electron beam characteristics, and accelerator operating parameters.

## 11. Measurement uncertainty

11.1 All dose measurements need to be accompanied by an estimate of uncertainty. Appropriate procedures are recommended in ISO/ASTM Guide 51707 (see also GUM).(15)

11.2 All components of uncertainty should be included in the estimate, including those arising from calibration, dosimeter reproducibility, instrument reproducibility, and the effect of influence quantities. A full quantitative analysis of components of uncertainty is referred to as an uncertainty budget, and is then often presented in the form of a table. Typically, the uncertainty budget will identify all significant components of uncertainty, together with their methods of estimation, statistical distributions and magnitudes.

11.3 The estimate of the expanded uncertainty achievable with measurements made using a routine dosimetry system such as calorimeters is typically of the order of 4 % ( $k = 2$ ), which corresponds approximately to a 95 % level of confidence for normally distributed data. Table 2 (9) gives examples of uncertainty components for a specific calorimetric system. The values in this table are not meant to be representative of other calorimetric systems or types and are only for illustrative purposes.

## 12. Keywords

12.1 absorbed dose; calibration; calorimeter; calorimetry; dosimeter; dosimetry; electron accelerator; electron beam;

**TABLE 2 Measurement uncertainties of routine polystyrene calorimetric dosimetry systems from Risø high dose reference laboratory (in percent, at  $k = 2$ ) (9)**

NOTE—At doses higher than 10 kGy, (2) and (3) are reduced to 0.2 %.

	Sources of Uncertainty	Type B	Type A
1	Calibration		3.2
2	Temperature measurement of calorimeter (at 3 kGy)	1.0	
3	Temperature extrapolation of calorimeter (at 3 kGy)	1.0	
4	Change of temperature sensitivity of specific heat of polystyrene		0.5
5	Heating effects	0.5	
	Quadratic sum	1.5	3.2
	Combined	3.6 %	

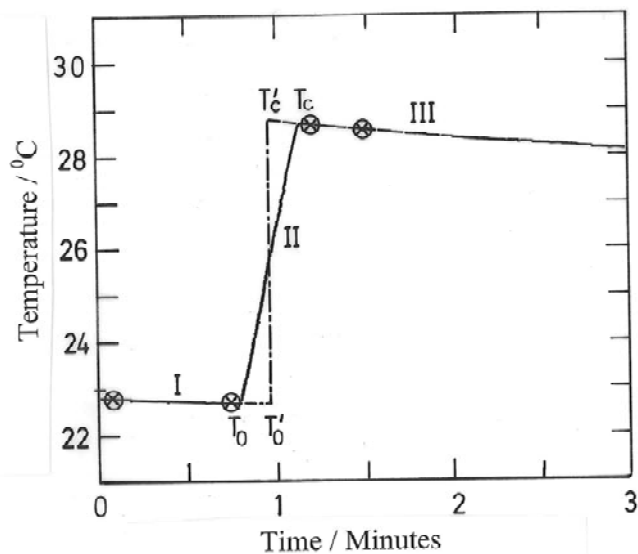

NOTE—Regions I, II, and III are before, during and after irradiation, respectively. The temperature curves were extrapolated from  $T_o$  and  $T_c$  to the midpoint of the irradiation time at  $T_o'$  and  $T_c'$ , respectively.  $\Delta T = T_c' - T_o'$  is used for dose calculation.

**FIG. 5 Example of on-line measurements of a graphite calorimeter (5)**

graphite; ionizing radiation; irradiation; polystyrene; radiation; radiation processing; water; ICS 17.240

## ANNEXES

### Informative

#### A1. EXAMPLE OF A CALIBRATION VERIFICATION OF CALORIMETRIC DOSIMETRY SYSTEMS

A1.1 Irradiation of calorimeters and transfer-standard dosimeters at an electron accelerator for verification of calibration.

A1.2 *Calorimeters*—Risø HDRL 10 MeV calorimeters (see Fig. 1)

A1.3 *Reference dosimeters*—Risø HDRL alanine pellets in holders. Alanine reference dosimeters were irradiated in standard phantoms (see Fig. 3)

A1.4 *Mode of irradiation*—Conveyor irradiation, in trays.

A1.5 *Dose calculation for calorimeters*:

$$\begin{aligned} \text{Dose} &= (T_2 - T_1 - T_a) \cdot F(T) \cdot k \\ &= (T_2 - T_1 - T_a) \cdot (C_1 + C_2 \cdot T) \cdot k \end{aligned}$$

where:

$$\begin{aligned} T_a &= 0.05^\circ\text{C} \\ C_1 &= 1.055 \\ C_2 &= 0.0108 \\ k &= 1.000 \end{aligned}$$

A1.6 Results for alanine and calorimeter dose measurements are given in Table A1.1.

**TABLE A1.1 Results for alanine and calorimeter dose measurements**

Cal. Ser. no.	Ref. Dos. no.	$D_{ref}$ kGy	$D_{cal}$ kGy	$D_{cal}/D_{ref}$
2571	099 - 100	32.00	32.20	1.006
2572	099 - 100	32.00	32.05	1.002
2573	099 - 100	32.00	32.00	1.000
Cal. Ser. no.	Ref. Dos. no.	$D_{ref}$ kGy	$D_{cal}$ kGy	$D_{cal}/D_{ref}$
2577	097 - 098	21.58	21.23	0.984
2581	097 - 098	21.58	21.26	0.985
2582	097 - 098	21.58	21.33	0.989
Cal. Ser. no.	Ref. Dos. no.	$D_{ref}$ kGy	$D_{cal}$ kGy	$D_{cal}/D_{ref}$
2583	095 - 096	10.09	10.06	0.997
2584	095 - 096	10.09	10.19	1.010
2587	095 - 096	10.09	10.20	1.011

A1.7 The results show agreement between doses measured with alanine reference dosimeters and the calorimeters with a maximum difference of 1.6 %. The result of calibration verification is accepted.

#### A2. SUPPLIERS OF CALORIMETRIC DOSIMETRY SYSTEMS

A2.1 Calorimeter suppliers are listed below. These suppliers also offer software for dose calculation:

A2.1.1 Risø High Dose Reference Laboratory  
Radiation Research Department  
Risø DTU  
Technical University of Denmark  
DK 4000 Roskilde  
Denmark

A2.1.2 GEX Corporation  
7330 S. Alton Way  
Suite 12-I  
Centennial CO 80112,  
USA

A2.1.3 Reference to these suppliers does not imply endorsement by ASTM or ISO.



## Bibliography

- (1) McLaughlin, W. L., Boyd, A. W., Chadwick, K. A., McDonald, J. C., and Miller, A., *Dosimetry for Radiation Processing*, Taylor and Francis, London, 1989.
- (2) Burns, D. T., and Morris, W. T., "Recent Developments in Graphite and Water Calorimeters for Electron Beam Dosimetry at NPL," *NRC Workshop on Water Calorimetry*, NRC Report 29637, National Research Council, Ottawa, Canada, 1988, p. 25.
- (3) Miller, A., "Dosimetry for Electron Beam Applications," Risø-M-2401, Risø National Laboratory, DK-4000 Roskilde, Denmark, 1983.
- (4) Miller, A., and Kovacs, A., "Calorimetry at Industrial Electron Accelerators," *Applications of Accelerators in Research and Industry '84*, Part II, Proceedings of 8th Conference, Denton, Texas, Nuclear Instruments and Methods, B10/11, 1985, p. 994.
- (5) Humphreys, J. C., and McLaughlin, W. L., "Calorimetry of Electron Beams and the Calibration of Dosimeters at High Doses," in *Radiation Processing: State of the Art*, Proceedings of 7th International Meeting, Noordwijkerhout, The Netherlands, 1989, Leemhorst, J. G. and Miller, A., Eds., *Radiation Physics and Chemistry*, Vol 35, 1990, p. 744.
- (6) Burns, D. T., and Morris, W. T., "A Graphite Calorimeter for Electron Beam Dosimetry," *High Dose Dosimetry for Radiation Processing*, IAEA, Vienna, 1991, p. 123.
- (7) Miller, A., and Kovacs, A., "Calibration and Routine Dosimetry for Industrial Electron Accelerators," *Proceedings of 4th Conference on Applications of Radioisotopes and Radiation Processing in Industry*, Leipzig, 1988.
- (8) Miller, A., and Kovacs, A., "Application of Calorimeters for Routine and Reference Dosimetry at 4-10 MeV Industrial Electron Accelerators," *Radiation Processing: State of the Art*, Vol II, Proceeding of 7th International Meeting, Noordwijkerhout, The Netherlands, 1989, Leemhorst, J. G. and Miller, A., Eds., *Radiation Physics and Chemistry*, Vol 35, 1990, p. 774.
- (9) Miller, A., "A Polystyrene Calorimeter for Electron Beam Dose Measurements," *Proceedings of the 9th International Meeting for Radiation Processing*, Istanbul, Turkey, Sept. 12-16, 1994, *Radiation Physics and Chemistry*, Vol 46, No. 4-6, 1995, p. 1243.
- (10) Sharpe, P. H. G., and Miller, A., "Guidelines for the Calibration of Dosimeters for Use in Radiation Processing," *CIRM-29*, National Physical Laboratory, Teddington, UK, 2009.
- (11) Skiens, W. E., "Sterilizing Radiation Effects on Selected Polymers," *Radiation Physics and Chemistry*, Vol 15, 1980, p. 47.
- (12) Domen, S. R., "Advances in Calorimetry for Radiation Dosimetry," *The Dosimetry of Ionizing Radiation*, Vol II (Eds. Kase, Bjärngard and Attix), 1987, p. 425.
- (13) Miller, A., Kovacs, A., and Kuntz, F., "Development of Polystyrene Calorimeter for Application at Electron Energies Down to 1.5 MeV," *Rad Phys Chem.*, Vol 63, 2002, p. 739.
- (14) Miller, A., Kovacs, A., Wieser, A., and Regulla, D. F., "Measurements with Alanine and Film Dosimeters for Industrial 10 MeV Electron Reference Dosimetry," *ESR Dosimetry and Applications*, Proceedings of 2nd International Symposium, Munich, 1988, Regulla, D. F., Scharmann, A., and McLaughlin, W. L., Eds., *Applied Radiation and Isotopes*, Vol 40, 1989, p. 967.
- (15) "Guide to the Expression of Uncertainty in Measurement," International Organization for Standardization, 1993, ISBN 92-67-10188-9. Available from The International Organization for Standardization, 1 rue de Varembé, Case Postale 56, CH-1211, Geneva 20, Switzerland.

ASTM International takes no position respecting the validity of any patent rights asserted in connection with any item mentioned in this standard. Users of this standard are expressly advised that determination of the validity of any such patent rights, and the risk of infringement of such rights, are entirely their own responsibility.

This standard is subject to revision at any time by the responsible technical committee and must be reviewed every five years and if not revised, either reapproved or withdrawn. Your comments are invited either for revision of this standard or for additional standards and should be addressed to ASTM International Headquarters. Your comments will receive careful consideration at a meeting of the responsible technical committee, which you may attend. If you feel that your comments have not received a fair hearing you should make your views known to the ASTM Committee on Standards, at the address shown below.

This standard is copyrighted by ISO, Case postale 56, CH-1211, Geneva 20, Switzerland, and ASTM International, 100 Barr Harbor Drive, PO Box C700, West Conshohocken, PA 19428-2959, United States. Individual reprints (single or multiple copies) of this standard may be obtained by contacting ASTM at the above address or at 610-832-9585 (phone), 610-832-9555 (fax), or service@astm.org (e-mail); or through the ASTM website ([www.astm.org](http://www.astm.org)). Permission rights to photocopy the standard may also be secured from the ASTM website ([www.astm.org/COPYRIGHT/](http://www.astm.org/COPYRIGHT/)).

---

**ICS 17.240**

Price based on 9 pages